

24.1 INTRODUCTION

A milling machine is a machine tool that removes metal as the work is fed against a rotating multipoint cutter. The milling cutter rotates at high speed and it removes metal at a very fast rate with the help of multiple cutting edges. One or more number of cutters can be mounted simultaneously on the arbor of milling machine. This is the reason that a milling machine finds wide application in production work. Milling machine is used for machining flat surfaces, contoured surfaces, surfaces of revolution, external and internal threads, and helical surfaces of various cross-sections. Typical components produced by a milling are given in Fig. 24.1. In many applications, due to its higher production rate and accuracy, milling machine has even replaced shapers and slotters.

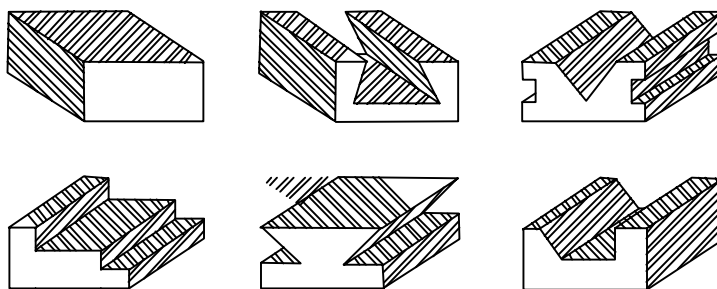

Fig. 24.1 Job surfaces generated by milling machine

24.2 PRINCIPLE OF MILLING

In milling machine, the metal is cut by means of a rotating cutter having multiple cutting edges. For cutting operation, the workpiece is fed against the rotary cutter. As the workpiece moves against the cutting edges of milling cutter, metal is removed in form chips of trochoid shape. Machined surface is formed in one or more passes of the work. The work to be machined is held in a vice, a rotary table, a three jaw chuck, an index head, between centers, in a special fixture or bolted to machine table. The rotatory speed of the cutting tool and the feed rate of the workpiece depend upon the type of material being machined.

24.3 MILLING METHODS

There are two distinct methods of milling classified as follows:

1. Up-milling or conventional milling, and
2. Down milling or climb milling.

24.3.1 UP-Milling or Conventional Milling Procedure

In the up-milling or conventional milling, as shown in Fig. 24.2, the metal is removed in form of small chips by a cutter rotating against the direction of travel of the workpiece. In this type of milling, the chip thickness is minimum at the start of the cut and maximum at the end of cut. As a result the cutting force also varies from zero to the maximum value per tooth movement of the milling cutter. The major disadvantages of up-milling process are the tendency of cutting force to lift the work from the fixtures and poor surface finish obtained. But being a safer process, it is commonly used method of milling.

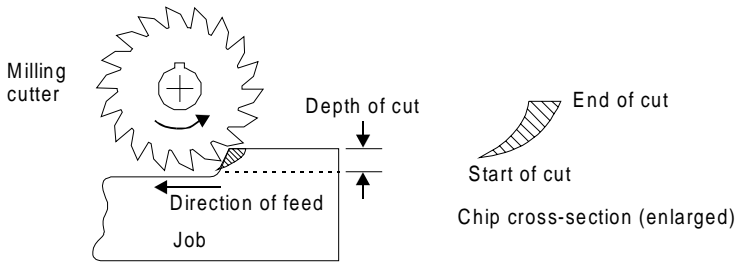

Fig. 24.2 Principal of up-milling

24.3.2 Down-Milling or Climb Milling

Down milling is shown in Fig. 24.3. It is also known as climb milling. In this method, the metal is removed by a cutter rotating in the same direction of feed of the workpiece. The effect of this is that the teeth cut downward instead of upwards. Chip thickness is maximum at the start of the cut and minimum in the end. In this method, it is claimed that there is less friction involved and consequently less heat is generated on the contact surface of the cutter and workpiece. Climb milling can be used advantageously on many kinds of work to increase the number of pieces per sharpening and to produce a better finish. With climb milling, saws cut long thin slots more satisfactorily than with standard milling. Another advantage is that slightly lower power consumption is obtainable by climb milling, since there is no need to drive the table against the cutter.

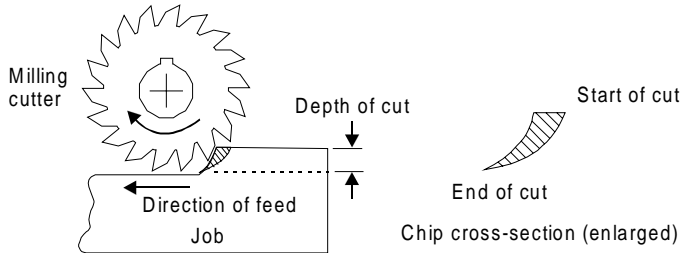

Fig. 24.3 Principal of down-milling

24.4 TYPES OF MILLING CUTTERS

Fig. 24.4 illustrates some types of milling cutters along with workpieces. Milling cutters are made in various forms to perform certain classes of work, and they may be classified as:

- (1) Plain milling cutters,
- (2) Side milling cutters,
- (3) Face milling cutter,
- (4) Angle milling cutters,
- (5) End milling cutter,
- (6) Fly cutter,
- (7) T-slot milling cutter,
- (8) Formed cutters,
- (9) Metal slitting saw,

Milling cutters may have teeth on the periphery or ends only, or on both the periphery and ends. Peripheral teeth may be straight or parallel to the cutter axis, or they may be helical, sometimes referred as spiral teeth.

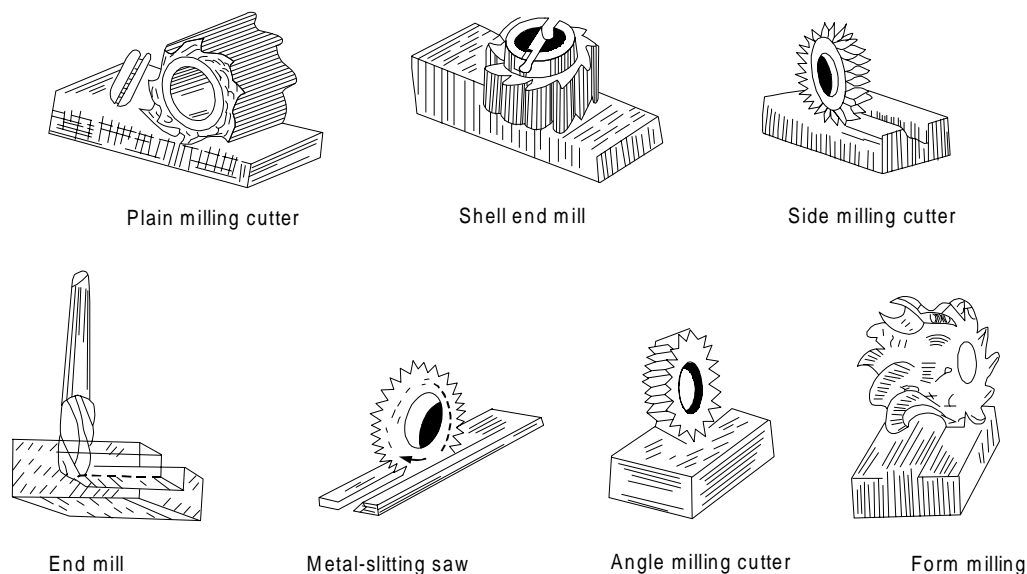

Fig. 24.4 Types of milling cutters

24.5 TYPES OF MILLING MACHINES

Milling machine rotates the cutter mounted on the arbor of the machine and at the same time automatically feed the work in the required direction. The milling machine may be classified in several forms, but the choice of any particular machine is determined primarily by the size of the workpiece to be undertaken and operations to be performed. With the above function or requirement in mind, milling machines are made in a variety of types and sizes. According to general design, the distinctive types of milling machines are:

- 1. Column and knee type milling machines
 - (a) Hand milling machine
 - (b) Horizontal milling machine (Fig. 24.5)
 - (c) Universal milling machine
 - (d) Vertical milling machine (Fig. 24.6)

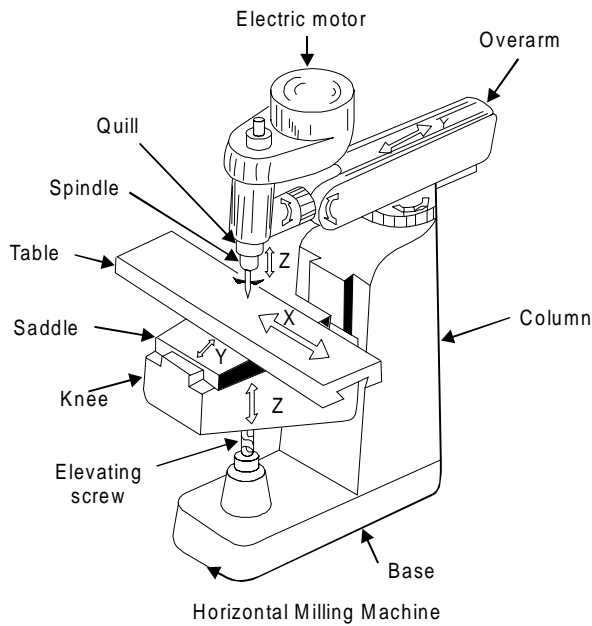

Fig. 24.5 Horizontal column and knee type milling machine

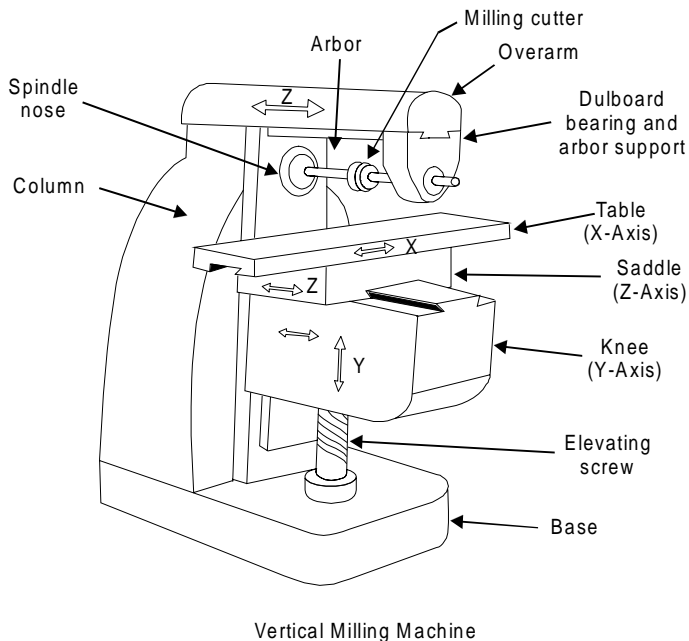

Fig. 24.6 Vertical column and knee type milling machine

2. Planer milling machine
3. Fixed-bed type milling machine
 - (a) Simplex milling machine.
 - (b) Duplex milling machine.
 - (c) Triplex milling machine.
4. Machining center machines
5. Special types of milling machines
 - (a) Rotary table milling machine.
 - (b) Planetary milling machine.
 - (c) Profiling machine.
 - (d) Duplicating machine.
 - (e) Pantograph milling machine.
 - (f) Continuous milling machine.
 - (g) Drum milling machine
 - (h) Profiling and tracer controlled milling machine

Some important types of milling machines are discussed as under.

24.5.1 Column and Knee Type Milling Machine

Fig. 24.7 shows a simple column and knee type milling machine. It is the most commonly used milling machine used for general shop work. In this type of milling machine the table

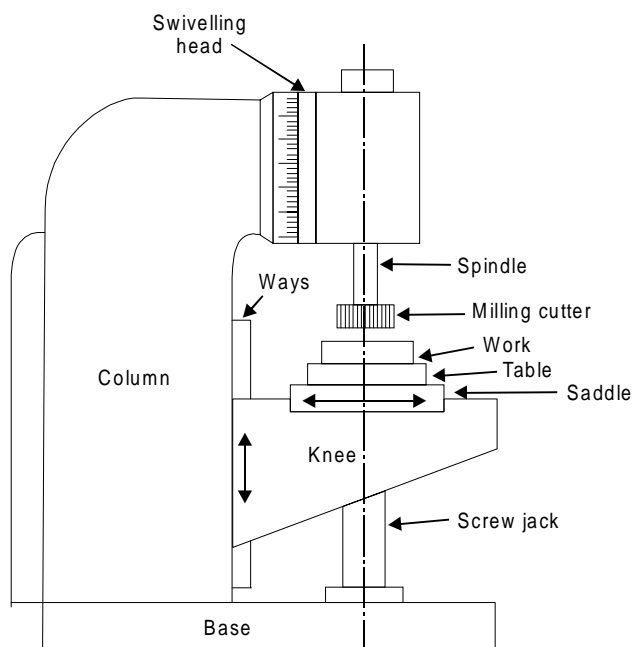

Fig. 24.7 A column and knee type milling machine

is mounted on the knee casting which in turn is mounted on the vertical slides of the main column. The knee is vertically adjustable on the column so that the table can be moved up and down to accommodate work of various heights. The column and knee type milling machines are classified on the basis of various methods of supplying power to the table, different movements of the table and different axis of rotation of the main spindle. Column and knee type milling machine comprises of the following important parts-

- | | |
|----------------------------|----------------------|
| 1. Base | 2. Column |
| 3. Saddle | 4. Table |
| 5. Elevating screw | 6. Knee |
| 7. Knee elevating handle | 8. Cross feed handle |
| 9. Front brace | 10. Arbor support |
| 11. Arbor | 12. Overhanging arm |
| 13. Cutter | 14. Cone pulley |
| 15. Telescopic feed shaft. | |

The principal parts of a column and knee type milling machine are described as under.

Base

It is a foundation member for all the other parts, which rest upon it. It carries the column at its one end. In some machines, the base is hollow and serves as a reservoir for cutting fluid.

Column

The column is the main supporting member mounted vertically on the base. It is box shaped, heavily ribbed inside and houses all the driving mechanism for the spindle and table feed. The front vertical face of the column is accurately machined and is provided with dovetail guideway for supporting the knee.

Knee

The knee is a rigid grey iron casting which slides up and down on the vertical ways of the column face. An elevating screw mounted on the base is used to adjust the height of the knee and it also supports the knee. The knee houses the feed mechanism of the table, and different controls to operate it.

Saddle

The saddle is placed on the top of the knee and it slides on guideways set exactly at 90° to the column face. The top of the saddle provides guide-ways for the table.

Table

The table rests on ways on the saddle and travels longitudinally. A lead screw under the table engages a nut on the saddle to move the table horizontally by hand or power. In universal machines, the table may also be swiveled horizontally. For this purpose the table is mounted on a circular base. The top of the table is accurately finished and T-slots are provided for clamping the work and other fixtures on it

Overhanging arm

It is mounted on the top of the column, which extends beyond the column face and serves as a bearing support for the other end of the arbor.

Front brace

It is an extra support, which is fitted between the knee and the over-arm to ensure further rigidity to the arbor and the knee.

Spindle

It is situated in the upper part of the column and receives power from the motor through belts, gears, and clutches and transmit it to the arbor.

Arbor

It is like an extension of the machine spindle on which milling cutters are securely mounted and rotated. The arbors are made with taper shanks for proper alignment with the machine spindles having taper holes at their nose. The draw bolt is used for managing for locking the arbor with the spindle and the whole assembly. The arbor assembly consists of the following components.

- | | |
|--------------------|-----------------|
| 1. Arbor | 2. Spindle |
| 3. Spacing collars | 4. Bearing bush |
| 5. Cutter | 6. Draw bolt |
| 7. Lock nut | 8. Key block |
| 9. Set screw | |

24.5.2 Planer Type Milling Machine

It is a heavy duty milling machine. It resembles a planer and like a planning machine it has a cross rail capable of being raised or lowered carrying the cutters, their heads, and the saddles, all supported by rigid uprights. There may be a number of independent spindles carrying cutters on the rail as two heads on the uprights. The use of the machine is limited to production work only and is considered ultimate in metal re-moving capacity.

24.5.3 Special Type Milling Machines

Milling machines of non-conventional design have been developed to suit special purposes. The features that they have in common are the spindle for rotating the cutter and provision for moving the tool or the work in different directions.

24.6 SIZE OF MILLING MACHINE

The size of the column and knee type milling machine is specified by

- (1) The dimensions of the working surface of the table, and
- (2) Its maximum length of longitudinal, cross and vertical travel of the table.

In addition to above, number of spindle speeds, number of feeds, spindle nose taper, power available, floor space required and net weight of machine will also be required for additional specification.

24.7 DEPTH OF CUT

The depth of cut in milling is defined as the thickness of the material removed in one pass of the work under the cutter. Thus it is the perpendicular distance measured between the original and final surface of the workpiece, and is expressed in mm.

24.8 INDEXING AND DIVIDING HEADS

Indexing is the operation of dividing the periphery of a piece of work into any number of equal parts. In cutting spur gear equal spacing of teeth on the gear blank is performed by indexing. Indexing is accomplished by using a special attachment known as dividing head or index head as shown in Fig. 24.8. The dividing heads are of three types:

- (1) Plain or simple dividing head,
- (2) Universal dividing head and
- (3) Optical dividing head.

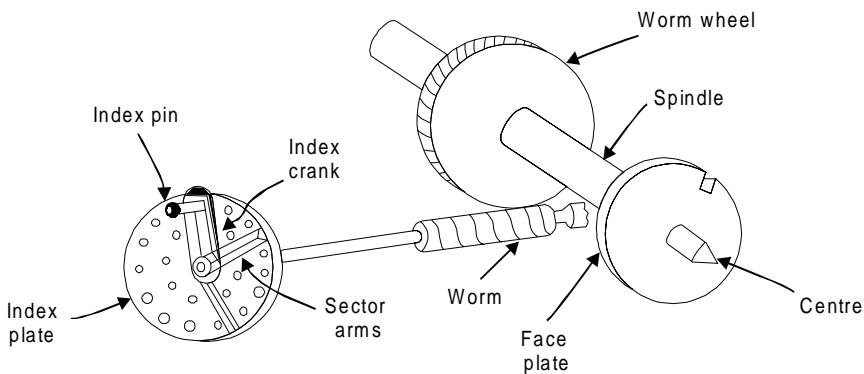

Fig. 24.8 Dividing head

24.8.1 Plain or Simple Dividing Head

The plain dividing head comprises a cylindrical spindle housed on a frame, and a base bolted to the machine table. The index crank is connected to the tail end of the spindle directly, and the crank and the spindle rotate as one unit. The index plate is mounted on the spindle and rotates with it. The spindle may be rotated through the desired angle and then clamped by inserting the clamping lever pin into anyone of the equally spaced holes or slots cut on the periphery of the index plate. This type of dividing head is used for handling large number of workpieces, which require a very small number of divisions on the periphery.

- | | |
|--------------------|-----------------|
| 1. Swiveling block | 2. Live centre |
| 3. Index crank | 4. Index plate. |

24.9 OPERATIONS PERFORMED ON MILLING MACHINE

Unlike a lathe, a milling cutter does not give a continuous cut, but begins with a sliding motion between the cutter and the work. Then follows a crushing movement, and then a cutting operation by which the chip is removed. Many different kinds of operations can be performed on a milling machine but a few of the more common operations will now be explained. These are:

Plain milling or slab milling

Fig. 24.9(a) illustrates the plain and slab milling operation. It is a method of producing a plain, flat, horizontal surface parallel to the axis of rotation of the cutter.

Face milling

Fig. 24.9(b) illustrates the face milling operation. It is a method of producing a flat surface at right angles to the axis of the cutter.

Side milling

Fig. 24.9(c) illustrates the side milling operation. It is the operation of production of a flat vertical surface on the side of a work-piece by using a side milling cutter.

Angular milling

Fig. 24.9(d) illustrates angular milling operation. It is a method of producing a flat surface making an angle to the axis of the cutter.

Gang-milling

Fig. 24.9(e) illustrates the gang milling operation. It is a method of milling by means of two or more cutters simultaneously having same or different diameters mounted on the arbor of the milling machine.

Form milling

Fig. 24.9(f) illustrates the form milling operation. It is, a method of producing a surface having an irregular outline.

End milling

Fig. 24.9(g) illustrates end milling operation. It is a method of milling slots, flat surfaces, and profiles by end mills.

Profile milling

Fig. 24.9(h) illustrates profile milling operation. It is the operation of reproduction of an outline of a template or complex shape of a master die on a workpiece.

Saw milling

Fig. 24.9(i) illustrates saw milling operation. It is a method of producing deep slots and cutting materials into the required length by slitting saws.

T-slot milling

Fig. 24.9(j) illustrates T-slot milling operation.

Keyway milling

Fig. 24.9(k) illustrates keyway milling operation.

Gear cutting milling

Fig. 24.9(l) illustrates gear cutting milling operation.

Helical milling

Fig. 24.9(m) illustrates helical milling operation.

Flute milling

It is a method of grooving or cutting of flutes on drills, reamers, taps, etc,

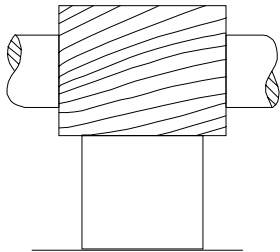

(a) Plane milling

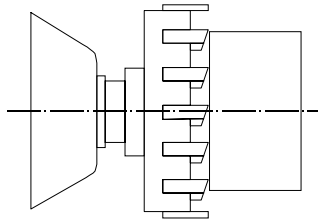

(b) Face milling

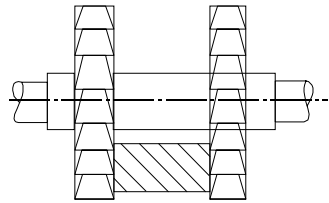

(c) Side milling

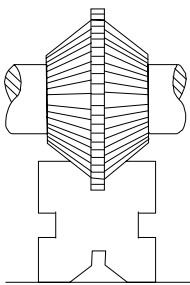

(d) Angular milling

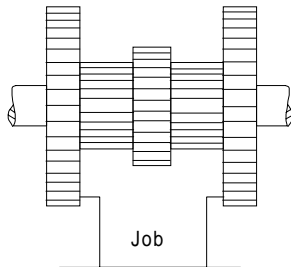

(e) Gang milling

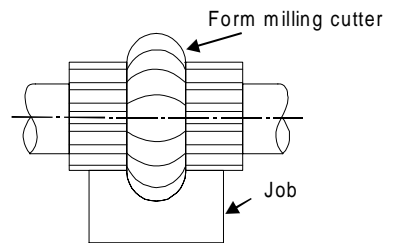

(f) Form Milling

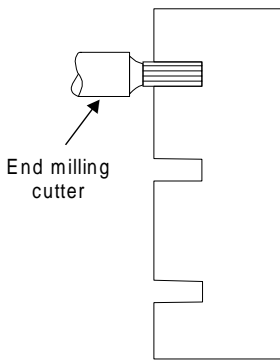

(g) End milling

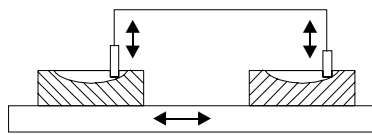

(h) Profile milling

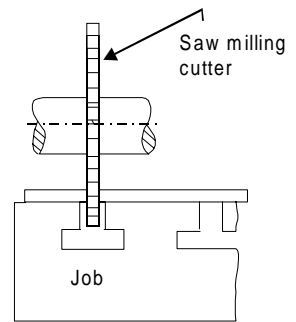

(i) Saw milling

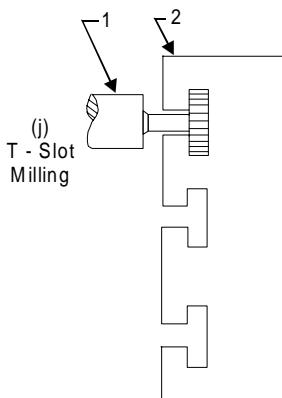

(j) T - Slot Milling

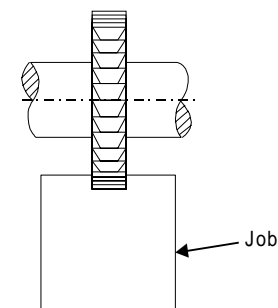

(k) Key way milling

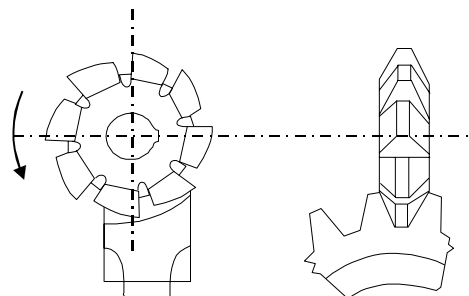

(l) Gear Cutting Milling

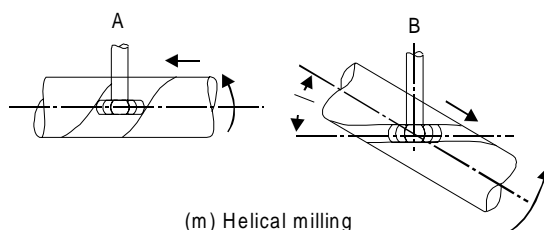

(m) Helical milling

Fig. 24.9 Various types of milling operations

Straddle milling

It is a method of milling two sides of a piece of work by employing two side-milling cutters at the same time.

Thread milling

It is a method of milling threads on dies, screws, worms, etc. both internally and externally. As an alternative to the screw cutting in a lathe, this method is being more extensively introduced now a day in modern machine shops.

24.10 QUESTIONS

1. State the working principle of milling machine.
2. How will you classify milling machines?
3. Using neat sketch, describe the principal parts of the milling machine by neat sketches.
4. Differentiate between up milling and down milling.
5. With the help of a neat sketch explain the column and knee type milling machine and name its main parts.
6. Explain various types of milling operations using neat sketches.
7. Describe thread milling.
8. Sketch and describe the indexing head used for gear cutting.
9. Explain the principle of differential indexing.
10. What is indexing? Describe direct indexing, with example.
11. Single angle milling cutter (b) Slot milling cutter (d) Convex milling cutter.
12. How will you index the gear teeth? Sketch the indexing set-up showing necessary calculations.
13. Sketch the machining set-up indicating tool work motions.
14. Sketch and specify the milling cutter indicating important tool geometry.
15. Define the following terms used in milling operation.
 - (a) Cutting speed
 - (b) Feed
 - (c) Depth of cut
 - (d) Machining time.